

- Ripple Fin<sup>®</sup> tubing
- Floating coil block suspension
- Eurovent certified
- Capacities according ENV 327 for R22



## Aircooled Condensers

# HTC

*New condenser generation with better performance*

Capacities 9 - 930 kW



# HELPMAN

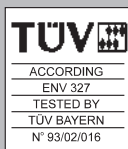

participant of the  
EUROVENT  
certification programme

## Air cooled condensers

**HTC**

## Contents

Page	
3	General information
4 - 9	Nominal duty air flow, sound levels technical data, dimensions
10	Fan types Fan motors
11	Capacity calculation Correction factors
12	Extended feet Additional information

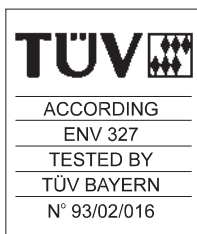

## Tested by TÜV

HTC aircooled condensers are tested by TÜV Bayern according to ENV 327 European standard.

This extensive testing procedure comprises :

- capacities under standardised conditions
- air flow data
- fan motor electrical data
- safety aspects
- sound levels according to DIN 45635

The TÜV registration number for HTC air cooled condensers is 93/02/016.

## Type indication

Example : **HTC 076 . 124 - 930**

- HTC** : Aircooled condenser with Cu/Al coil block
- 076** : Condenser type  
There are 4 basic types with different fan diameters
- 1••** : Number of separated coils
- 2•** : Number of fans per coil
- 4** : Number of tube rows in air direction
- 930** : Fan speed

## Air cooled condensers

HTC



### General

The HTC aircooled condenser range includes 4 basic types covering a total of 107 models with 1 to 12 fans and duties from 9 to 930 kW at 15 K temperature difference.

### Design

Coil block	: Copper Ripple Fin® tubing with aluminium fins.
Tube diameter	: ½"
Tube thickness	: 0.65 mm/0.4 mm (min.)
Tube pitch	: 50 x 50 mm triangle
Fin spacing	: 2.25 mm

Other fin spacings up to 4 mm available on request.

Coil blocks are pressure tested at 28 bar dry air.

Casing and framework are of pregalvanised sheet steel (Sendzimir) with an epoxy coating on both sides. Colour scheme: light-grey RAL 7035, mounting feet models 076, 080 and 100, dark-grey RAL 7016. Other colours are available at an extra price. All condensers are provided with removable header panels.

#### Condenser models 076, 080 and 100

Floating construction of the condenser coil block. On request the condensers can be fitted with inspection hatches (extra price).

### Air direction

Condensers type HTC can be supplied for horizontal or vertical air flow.

#### Condenser models 050 :

Standard horizontal air flow, vertical air flow with special refrigerant circuiting. All models are fitted with mounting profiles.

#### Condenser models 076, 080 and 100 :

Standard vertical air flow. On request also available for horizontal air flow.

When ordering without air flow indication, the standard execution will be supplied.

### Corrosion protection

The standard condensers have a high corrosion resistance through selected materials, surface treatment and construction. For application in aggressive surroundings (coastal and industrial areas) following designs are available at an extra charge:

- fins of seawater resistant aluminium alloy (57S/5052)
- fins of prepainted aluminium
- finned coils chromated after assembling
- copper fins (delivery time on request)

### Application as liquid cooler (Dry - Cooler)

The condenser can also be used as liquid cooler, for instance cooling down of cooling water in watercooled plants.

Technical information on request, see brochure nr. 53.08 (Dry Coolers HTD).

Air cooled condensers

HTC

Capacities HTC ●●● . 1●●

Type	Capacity kW		Airflow m <sup>3</sup> /h		dB(A)	Capacity kW		Airflow m <sup>3</sup> /h		dB(A)	Cap.	Air	dB(A)	Cap.	Air	dB(A)	
HTC	H	L	H	L	H/L	H	L	H	L	H/L							
<b>Motor 370 W, 1420 rpm</b>					<b>180 W, 910 rpm</b>					<b>120 W, 690 rpm</b>			<b>25 W, 470 rpm</b>				
050 . 112 - ...	15.7		6640		55	13.5		5030		44	12.0	4100	40	8.9	2530	31	
050 . 113 - ...	20.1		6400		55	16.9		4860		44	15.5	3950	40	10.7	2380	31	
050 . 114 - ...	23.0		6200		55	19.0		4660		44	15.8	3620	40	11.1	2160	31	
050 . 122 - ...	31.7		13300		58	27.2		10100		47	24.1	8200	43	17.8	5050	34	
050 . 123 - ...	42.8		12800		58	35.9		9730		47	31.2	7900	43	21.5	4770	34	
050 . 124 - ...	46.3		12400		58	38.2		9310		47	33.7	7240	43	22.1	4320	34	
050 . 132 - ...	44.5		19900		60	43.4		15100		49	38.5	12300	45	28.1	7580	36	
050 . 133 - ...	64.5		19200		60	54.0		14600		49	46.9	11900	45	33.3	7150	36	
050 . 134 - ...	73.5		18600		60	60.1		14000		49	49.6	10900	45	33.8	6480	36	
050 . 143 - ...	86.3		25600		61	72.2		19500		50	64.0	15800	46	44.3	9540	37	
050 . 144 - ...	92.8		24800		61	82.0		18600		50	67.8	14500	46	44.3	8640	37	
<b>Motor 750 W, 930 rpm</b>					<b>750/150 W, 935/425 rpm</b>					<b>370 W, 690 rpm</b>			<b>120 W, 325 rpm</b>				
076 . 112 - ...	35.4		14700		53	35.4	21.9	14700	7280	53/39	29.2	10400	46	20.1	6340	33	
076 . 113 - ...	45.8		13900		53	45.8	27.2	13900	7110	53/39	36.7	9790	46	22.9	5630	33	
076 . 114 - ...	50.1		13100		53	50.1	30.7	13100	6950	53/39	41.3	9290	46	23.3	4950	33	
076 . 122 - ...	71.2 *		29300		56	71.2 *	46.6	29300	14600	56/42	58.6 *	20700	49	42.4	12700	36	
076 . 123 - ...	92.1		27700		56	92.1	56.7	27700	14200	56/42	73.4	19600	49	47.3	11300	36	
076 . 124 - ...	106.4		26200		56	106.4	61.7	26200	13900	56/42	83.1	18600	49	46.3	9910	36	
076 . 132 - ...	110.6		44000		58	110.6	68.0	44000	21900	58/44	90.7	31100	51	61.8	19000	38	
076 . 133 - ...	138.6		41600		58	138.6	84.7	41600	21300	58/44	114.9	29400	51	70.5	16900	38	
076 . 134 - ...	154.9		39400		58	154.9	93.3	39400	20900	58/44	121.4	27900	51	70.0	14900	38	
076 . 142 - ...	135.8		58600		59	135.8	93.8	58600	29100	59/45	124.9	41500	52	85.3	25400	39	
076 . 143 - ...	191.3		55400		59	191.3	111.9	55400	28400	59/45	151.9	39200	52	95.4	22500	39	
076 . 144 - ...	213.6		52500		59	213.6	122.1	52500	27800	59/45	166.3	37200	52	93.9	19800	39	
076 . 152 - ...	178.7		73300		60	178.7	119.0	73300	36400	60/46	146.6	51800	53	108.4	31700	40	
076 . 153 - ...	237.9 *		69300		60	237.9 *	142.6	69300	35600	60/46	193.2	49000	53	119.1	28100	40	
076 . 154 - ...	270.9		65600		60	270.9	155.3	65600	34800	60/46	211.3	46400	53	116.3	24800	40	
076 . 162 - ...	221.9		87900		61	221.9	136.2	87900	43700	61/47	181.6	62200	54	123.8	38000	41	
076 . 163 - ...	289.7 *		83200		61	289.7 *	172.2	83200	42700	61/47	221.1	58700	54	143.7	33800	41	
076 . 164 - ...	310.5		78700		61	310.5	186.8	78700	41700	61/47	243.0	55700	54	140.6	29700	41	
<b>Motor 1400/810 W, 870/620 rpm</b>					<b>720/440 W, 680/500 rpm</b>												
080 . 112 - ...	41.9	38.2	18700	13800	57/48	39.3	34.7	14600	13000	50/41							
080 . 113 - ...	57.0	46.3	17600	12700	57/48	48.0	41.4	13400	12000	50/41							
080 . 114 - ...	64.5	52.0	16700	11900	57/48	53.9	45.8	12500	11200	50/41							
080 . 122 - ...	91.1	76.9	37400	27700	60/51	79.4	69.7	29200	26000	53/44							
080 . 123 - ...	114.8	92.9	35300	25500	60/51	96.2	83.3	26800	24000	53/44							
080 . 124 - ...	133.4	104.4	33500	23800	60/51	108.5	92.4	25000	22400	53/44							
080 . 132 - ...	137.3	115.8	56100	41500	62/53	119.4	104.9	43700	39000	55/46							
080 . 133 - ...	172.3	139.6	52900	38200	62/53	150.5	129.7	40200	36000	55/46							
080 . 134 - ...	194.4	158.4	50200	35700	62/53	164.3	139.6	37500	33600	55/46							
080 . 142 - ...	168.5	143.0	74900	55300	63/54	164.5	144.8	58300	52000	56/47							
080 . 143 - ...	230.1	192.7	70500	51000	63/54	199.6	172.3	53700	47900	56/47							
080 . 144 - ...	268.2	210.0	67000	47600	63/54	217.7	184.7	50000	44700	56/47							
080 . 152 - ...	221.8	187.3	93600	69200	64/55	193.0	169.9	72900	65000	57/48							
080 . 153 - ...	296.2 *	240.1 *	88200	63700	64/55	248.3 *	213.9 *	67100	59900	57/48							
080 . 154 - ...	333.6 *	266.4	83700	59500	64/55	276.0	234.1	62600	55900	57/48							
<b>Motor 1950/1350 W, 670/520 rpm</b>					<b>380/190 W, 300/180 rpm</b>												
100 . 112 - ...	56.7	47.9	27400	19900	55/47	36.4	27.2	12400	7300	36/27							
100 . 113 - ...	71.9	59.0	25100	18100	55/47	43.7	29.7	10800	6270	36/27							
100 . 114 - ...	86.1	70.5	23300	16200	55/47	49.0	32.2	9660	5750	36/27							
100 . 122 - ...	114.1	96.2	54700	39900	58/50	77.1	55.6	24800	14600	39/30							
100 . 123 - ...	144.1	124.9	50100	36200	58/50	87.9	59.5	21500	12500	39/30							
100 . 124 - ...	182.0	142.2	46500	32300	58/50	97.7	64.7	19300	11500	39/30							
100 . 132 - ...	160.0	153.4	82100	59800	60/52	116.1	83.8	37200	21900	41/32							
100 . 133 - ...	229.6	188.1	75200	54300	60/52	134.8	89.8	32300	18800	41/32							
100 . 134 - ...	274.2	213.2	69800	48500	60/52	144.8	96.9	29000	17300	41/32							
100 . 142 - ...	228.9	192.9	109500	79700	61/53	158.0	111.8	49600	29200	42/33							
100 . 143 - ...	307.1 *	250.6 *	100200	72400	61/53	179.8	120.4	43000	25100	42/33							
100 . 144 - ...	366.4 *	291.0	93100	64700	61/53	196.2	128.0	38600	23000	42/33							
100 . 152 - ...	298.2	250.8	136900	99600	62/54	189.2	140.9	62000	36500	43/34							
100 . 153 - ...	375.9	306.6	125300	90500	62/54	215.6	150.5	53800	31300	43/34							
100 . 154 - ...	466.2 *	363.1 *	116300	80800	62/54	247.8	161.1	48300	28800	43/34							

H = High fan speed

L = Low fan speed

★ For these condenser models the connections are located at both ends (liquid header is replaced). The other condenser models have both connections (inlet and outlet) at one end.

# Air cooled condensers

**HTC**

## Technical Data HTC ●●● . 1●●

Type HTC	Refrigerant connections mm ODS		Internal volume dm <sup>3</sup>	Surface m <sup>2</sup>	Weight kg fin execution		Dimensions mm			
	in	out			aluminium	copper	A	B	CD	
050 . 112 - ...	1 x 22	1 x 22	5	47	43	54				
050 . 113 - ...	1 x 22	1 x 22	7	70	52	70	1060	830		
050 . 114 - ...	1 x 22	1 x 22	9	93	61	85				
050 . 122 - ...	1 x 22	1 x 22	8	93	84	108				
050 . 123 - ...	1 x 28	1 x 28	12	140	101	137	1860	1630		
050 . 124 - ...	1 x 28	1 x 28	16	187	118	166				
050 . 132 - ...	1 x 28	1 x 28	11	140	125	161				
050 . 133 - ...	1 x 35	1 x 35	16	210	150	204	2660	2430		
050 . 134 - ...	1 x 35	1 x 35	22	280	176	247				
050 . 143 - ...	1 x 35	1 x 35	24	280	203	275				
050 . 144 - ...	1 x 42	1 x 42	31	373	237	333	3460	3230		
076 . 112 - ...	1 x 28	1 x 28	9	102	128	154				
076 . 113 - ...	1 x 28	1 x 28	13	153	146	186	2000	1340		1 x 1400
076 . 114 - ...	1 x 28	1 x 28	17	204	165	218				
076 . 122 - ...	1 x 35	1 x 35	16	204	253	305				
076 . 123 - ...	1 x 42	1 x 42	24	306	290	368	3400	2740		2 x 1400
076 . 124 - ...	1 x 42	1 x 42	31	408	326	431				
076 . 132 - ...	1 x 42	1 x 42	25	306	381	459				
076 . 133 - ...	1 x 54	1 x 54	36	459	436	554	4800	4140		3 x 1400
076 . 134 - ...	1 x 54	1 x 54	49	612	492	649				
076 . 142 - ...	1 x 54	1 x 54	32	408	506	611				
076 . 143 - ...	1 x 54	1 x 54	48	612	580	737	6200	5540	2740	4 x 1400
076 . 144 - ...	1 x 67	1 x 67	63	817	653	862				
076 . 152 - ...	1 x 54	1 x 54	39	510	632	763				
076 . 153 - ...	1 x 67	1 x 67	58	766	723	919	7600	6940	4140	5 x 1400
076 . 154 - ...	1 x 67	1 x 67	77	1021	814	1075				
076 . 162 - ...	1 x 67	1 x 67	46	612	757	914				
076 . 163 - ...	1 x 67	1 x 67	69	919	866	1101	9000	8340	4140	6 x 1400
076 . 164 - ...	1 x 67	1 x 67	91	1225	974	1289				
080 . 112 - ...	1 x 28	1 x 28	10	122	230	262				
080 . 113 - ...	1 x 35	1 x 35	16	184	253	300	2000	1340		1 x 1400
080 . 114 - ...	1 x 35	1 x 35	21	245	275	338				
080 . 122 - ...	1 x 42	1 x 42	19	245	458	520				
080 . 123 - ...	1 x 42	1 x 42	28	367	501	596	3400	2740		2 x 1400
080 . 124 - ...	1 x 54	1 x 54	38	490	545	671				
080 . 132 - ...	1 x 54	1 x 54	30	367	688	782				
080 . 133 - ...	1 x 54	1 x 54	44	551	755	896	4800	4140		3 x 1400
080 . 134 - ...	1 x 54	1 x 54	59	735	821	1010				
080 . 142 - ...	1 x 54	1 x 54	38	490	916	1041				
080 . 143 - ...	1 x 67	1 x 67	57	735	1003	1192	6200	5540	2740	4 x 1400
080 . 144 - ...	1 x 67	1 x 67	76	980	1091	1343				
080 . 152 - ...	1 x 67	1 x 67	46	612	1143	1300				
080 . 153 - ...	1 x 67	1 x 67	70	919	1252	1488	7600	6940	4140	5 x 1400
080 . 154 - ...	1 x 80	1 x 80	93	1226	1361	1675				
100 . 112 - ...	1 x 35	1 x 35	13	152	251	290				
100 . 113 - ...	1 x 35	1 x 35	19	228	279	338	2350	1690		1 x 1750
100 . 114 - ...	1 x 42	1 x 42	25	304	307	385				
100 . 122 - ...	1 x 42	1 x 42	25	304	502	580				
100 . 123 - ...	1 x 54	1 x 54	38	457	558	676	4100	3440		2 x 1750
100 . 124 - ...	1 x 54	1 x 54	51	607	614	771				
100 . 132 - ...	1 x 54	1 x 54	36	455	750	868				
100 . 133 - ...	1 x 67	1 x 67	54	685	832	1009	5850	5190		3 x 1750
100 . 134 - ...	1 x 67	1 x 67	72	911	915	1151				
100 . 142 - ...	1 x 67	1 x 67	46	607	998	1155				
100 . 143 - ...	1 x 67	1 x 67	70	913	1107	1343	7600	6940	3440	4 x 1750
100 . 144 - ...	1 x 80	1 x 80	93	1214	1216	1530				
100 . 152 - ...	1 x 67	1 x 67	57	759	1246	1443				
100 . 153 - ...	1 x 80	1 x 80	86	1142	1382	1677	9350	8690	5190 *	5 x 1750
100 . 154 - ...	1 x 80	1 x 80	114	1518	1518	1910				

\* execution with copper fins: 8 feet at distances 3440, 1810, 3440 mm

Air cooled condensers

HTC

HTC 050 . 1•• Horizontal Air Direction

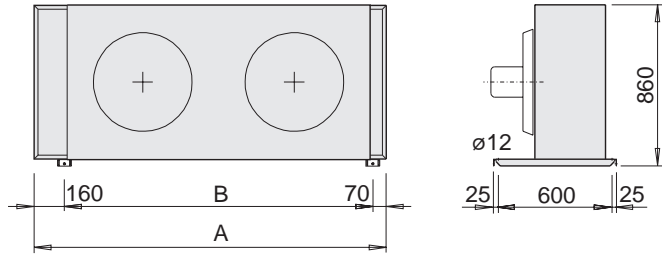

HTC 050 . 1•• Vertical Air Direction

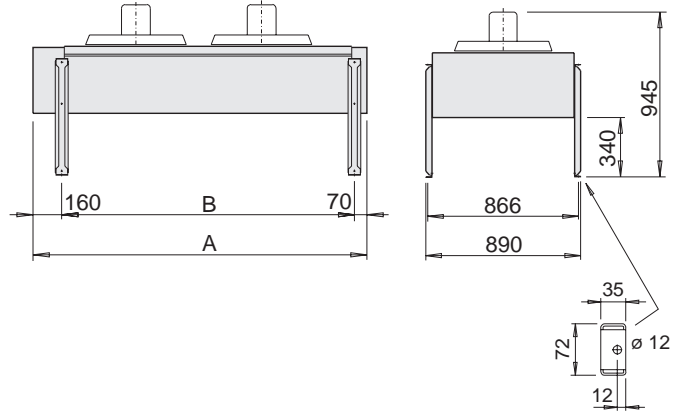

HTC 076 . 1••

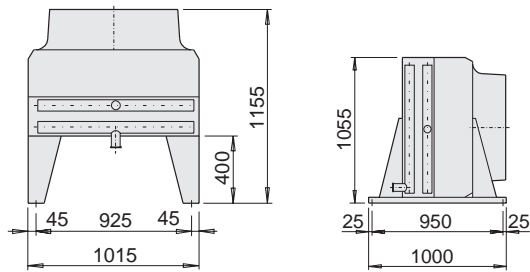

HTC 076 / 080 / 100 . 1•• Vertical Air Direction

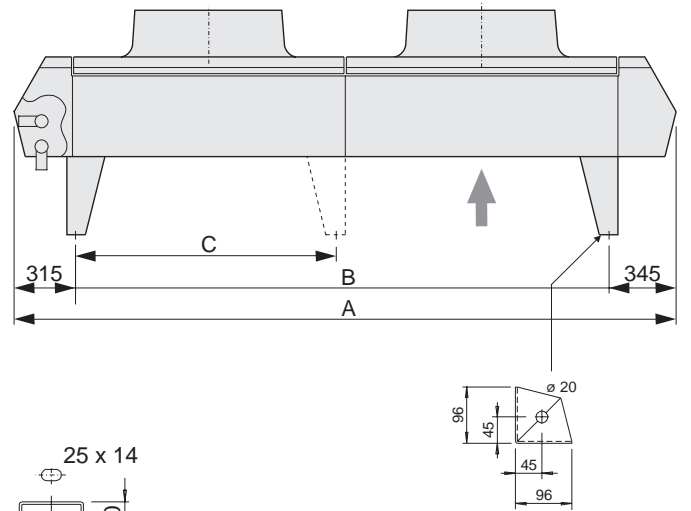

HTC 080 . 1••

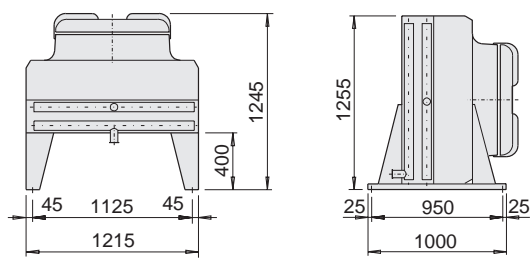

HTC 076 / 080 / 100 . 1•• Horizontal Air Direction

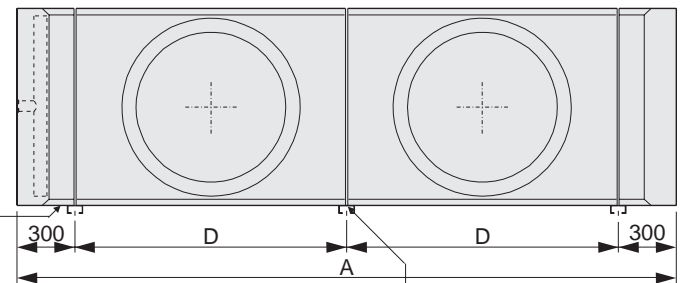

HTC 100 . 1••

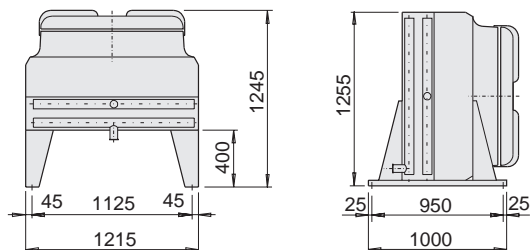

Supports for every module

## Air cooled condensers

**HTC**

### Fan types

All fan types have corrosion resistant fan blades and fan guards.

#### HTC Type 050

Fans ø 508 mm, complete with protection guards and anti vibration mountings.

The guards are galvanized and epoxy coated.

Mounting bolts and nuts are stainless steel.

Standard execution with fan motors type 050.910.

Terminal boxes are provided with cable inlet PG-13,5.

#### HTC Type 076

Fans ø 762 mm mounted on a motor support.

Fan guards are integrated in the fan plate.

Standard execution with fan motors type 076.930.

Motors are wired to one or more common terminal boxes.

The terminal boxes are located on the endplate at the liquid header end of the coil.

#### HTC Type 080

Fans ø 800 mm, fan motors integrated with guards and mounted to fan discharge hood.

#### HTC Type 100

Similar in construction to type 080, fan diameter however 1000 mm.

All fan motors of HTC models **080** and **100** are equipped with an overload protector built in the windings. Via terminals in the terminal box this internal protector **must** be used in the control current circuit. The electrical control should be arranged in such a way that continuous on/off switching of the motors ('tripping') is prevented.

When the condensers are out of use for longer periods, the motors have to be switched on for at least 2 hours every month.

#### HTC All Models

For application at ambient temperatures above 40 °C : special motors on request.

### Fan motors

Motor type	Number of poles	rpm	Capacity		Motor voltage Volt	Thermal overload relay settings (A) *
			nomi- nal Watt	absor- bed Watt		
<b>HTC type 050</b> (enclosed design, IP-55)						
050 . 910	6	910	180	350	220/380/50/3	1.49 / 0.86
050 . 690	8	690	120	250	220/380/50/3	1.16 / 0.67
050 . 470	12	470	25	100	220/380/50/3	0.55 / 0.32
050 . 1420	4	1420	370	600	220-240/380-415/50/3	2.42 / 1.40
050 . VAR	6	var.	180	350	220/50/1	2.36 **
<b>HTC type 076</b> (enclosed design, IP-55)						
076 . 930	6	930	750	1170	220-240/380-415/50/3	5.0 / 2.9
076 . 690	8	690	370	560	220-240/380-415/50/3	2.6 / 1.5
076 . 325	16	325	120	250	220-240/380-415/50/3	2.0 / 1.2
076 . 425 YI	6	935	750	1420	380-415/50/3	3.1
	YII	12	425	150	380-415/50/3	1.1
076 . 930 M	6	930	750	1170	220-240/50/1	8.0
076 . VAR	6	var.	750	1000	220-240/50/1	8.4 **
076 . 840	8	840	660	770	220-254/380-440/60/3	4.8 / 2.8
<b>HTC type 080</b> (enclosed design, IP-54)						
080 . 870 Δ	-	870		1400	380/50/3	3.2
	Y	620		810	380/50/3	1.9
080 . 680 Δ	-	680		720	380/50/3	2.2
	Y	500		440	380/50/3	1.1
<b>HTC type 100</b> (enclosed design, IP-54)						
100 . 670 Δ	-	670		1950	380/50/3	4.6
	Y	520		1350	380/50/3	3.0
100 . 300 Δ	-	300		380	380/50/3	1.10
	Y	180		190	380/50/3	0.61

\* The settings can be applied to a minimum ambient temperature of -10 °C

\*\* Value at highest speed.

# Air cooled condensers

# HTC

## Factors for calculation of the condenser capacity

The condenser capacity is the compressor capacity multiplied with the factor from the diagram. The diagrams are valid for R 22 and R 134 a. At evaporating temperatures below -20 °C the condenser capacity has to be calculated from the compressor capacity at -20 °C, or a starting control should be used to protect the compressors from high starting loads.

OPEN compressors

SEMI-HERMETIC compressors  
(motor air/water cooled)

Factor

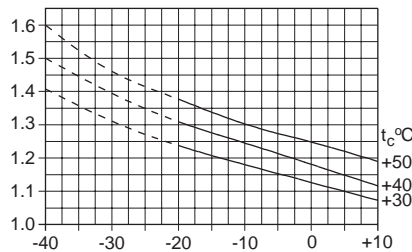

Evaporating temperature °C

SEMI-HERMETIC compressors  
(motor suctiongas cooled)

HERMETIC compressors

Factor

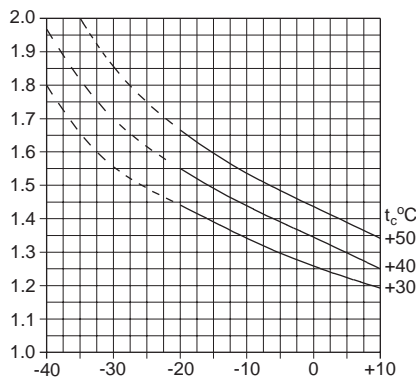

Evaporating temperature °C

## Capacity

The basic capacity ratings (pages 4 and 7) are for R22 at a  $t_d^*$  of 15 K and ambient temperatures up to 25 °C.

\*  $t_d$  = difference between condensing- and ambient temperature.

Capacities are directly proportional with other temperature differences between 10 and 20 K.

The refrigerant circuiting is optimised to the selected fan speed. When selecting a condenser model with two fan speeds a 'first choice' fan speed has to be given to which the refrigerant circuiting will be designed. The condenser capacity for the 'second choice' fan speed can be up to 10 % below the stated capacity.

## Correction factors

		Factor
Refrigerant R 134a		0.95
Ambient temperature :	25 °C	1.00
	35 °C	0.96
	40 °C	0.94
(special motor)	50 °C	0.91
Altitude above sea level :	0 m	1.00
	500 m	0.97
	1000 m	0.93
	1500 m	0.90
	2000 m	0.86
	2500 m	0.83
Application of motors suitable for 60 Hz with n = 840 rpm		0.95

Example : **HTC 2 . 124 - 840**

What is the condenser capacity at an ambient temperature of 40 °C, refrigerant R22, altitude at sea level and equipped with motors for 60 Hz ?

Nominal capacity at 15 K tv : 106.4 kW

Correction factors :

t = 40 °C : 0.94  
 altitude sea level : 1.00  
 60 Hz motors : 0.95

Corrected capacity :

0.94 x 1.00 x 0.95 x 106.4 = 95.0 kW

## Capacity control

For multifan models capacity can be controlled by cycling one or more fans. Capacity control on all models is also possible by using 2-speed or speed regulated single phase motors (in combination with an electronic speed control device).

The fan compartments are separated by baffle plates.

## Multi circuiting

Condensers can be supplied (at extra cost) with multi circuiting.



# Air cooled condensers

HTC

## Soundlevels dB(A)

The soundlevels in the tables on pages 4 and 7 are the results of tests according to DIN 45635. The values are measured in the horizontal plane at a distance of 10 m. More information on request.

The table below gives sound level corrections at various distances.

Distance m	Correction dB(A)
1	+ 20
2	+ 14
3	+ 10
4	+ 8
5	+ 6
10	0
20	- 6
50	- 14
100	- 20

## Location

### Air movement

Condensers should be positioned to achieve the following criteria :

- Adequate space (min. 1.0 metre) must be left for free entry to the coil inlet face.
- No restrictions to the air discharge.
- No possibility of direct air recirculation (short circuiting of air).

## Installation and maintenance

For more information on installation and maintenance of air cooled condensers model HTC we refer to our brochure nr. 88.02 ( "Installation and Maintenance Instructions for Aircooled Condensers" ).

This brochure is issued with every condenser.

## Extended feet

Extended feet can be supplied as optional extra for condenser models 076, 080 and 100. These feet are supplied separately. The standard feet height gives 400 mm free space under the condenser. Extended feet are available for heights of 600 mm.

## Transport

All models are provided with lifting lugs. To avoid damage during hoisting, a hoisting beam should be used, by which the given angles are to be considered. Beware of shocks during transport and handling (sudden lifting).

## Mounting

Refrigerant pipework connections are to be soldered free of tension.

When connecting more than one condenser in parallel the pressure drop on the refrigerant side has to be considered.

